

CONTROL VALVES



VALVE SOLUTIONS for Corrosive Applications



AUTHORISED DISTRIBUTOR FOR
Australia/NZ/PNG/Philippines

RHINO FLEX™

RHINOFLEX VALVE SOLUTIONS PTY.LTD

4/7 Holder Way, Malaga, W.A 6090

Phone: +61 -08 61130808

sales@rfvs.com.au



UNPPolyvalves

Manufacturer of PFA/FEP/PTFE Lined & Plastic Valves,
Pipes & Pipe Fittings



VALVE SOLUTIONS for Corrosive Applications



ABOUT US

UNP Polyvalves is manufacturing and supplying valve solutions for corrosive applications since 1988.

Considering Indian market not having a good valve manufacturing plants for corrosive application valves in 80's and huge project requirements coming up during these years UNP promoters decided to install a corrosive application valve manufacturing plant in Vadodara, Gujarat.

UNP with its possession of highly knowledgeable and skilled work force along with technically qualified and experienced promoters having vision to grow and guide their team to be the world leading brand, market leaders and make products which are high in performance and having unmatched quality and reliability, has excelled in all these requirements of market.

Taking up the challenge UNP started its first manufacturing plant just admeasuring 1600 square feet, it started with manufacturing of solid plastic valves in very few options in terms of material of construction, type of valves and size range.

UNP started working very closely with the chemical process industries in India, Understanding their difficulties and requirements UNP always worked towards solutions to the problems in industries and earned very good name not only in domestic market but also in international market.

UNP understanding the changing market trends and requirements, entered in the business of Lined Valves and Piping systems in the year 1992 and has now become a leading brand in providing most reliable Lined Valves and Piping system to the chemical process industries.

Envisioned for quality and reliability, UNP Polyvalves aims for highest level of customer satisfaction through its solutions with commitment for excellence in all spheres of business.

UNP today provides both Solid Plastic and Lined, Ball Valves, Plug Valves, Butterfly Valves, Diaphragm Valves, Ball Check Valves, Swing Check Valves, Sampling Valves, Double Window and Full View Sight Glasses, Y and T type strainers, Lined Pipes and Fittings with sizes ranging from ½" to 24".

UNP has marked its presence across the globe and are having establishments in countries like North America and exporting to 35+ countries through its distribution networks and to the direct end users.

ACHIEVEMENTS

UNP through its knowledge about the exact process conditions and technical expertise has helped chemical industries in resolving their corrosion problems and operational problems related to Plastic valves, Lined Valves and Piping systems. Chlor Alkali Plants, Pickling Lines and Acid regeneration plants in steel industries, Chemical injection skid manufacturers in Oil and Gas industries and many other plants having corrosion problems have been benefited by our knowledge and expertise.

UNP is approved brand by leading consulting and EPC companies such as UHDE, JACOBS Engineering, Mott McDonalds, Toyo Engineering, Fluor Daniel, EIL etc and have worked for their very prestigious project over these years.

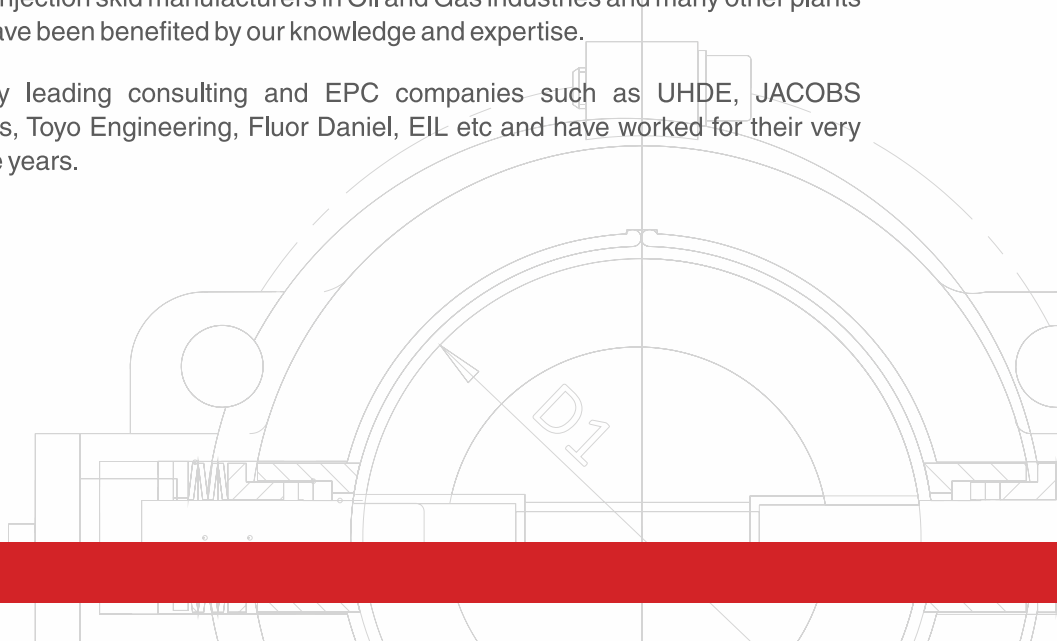

BALL ON-OFF & CONTROL VALVE

BALL VALVE (ON-OFF)



SECTIONAL VIEW

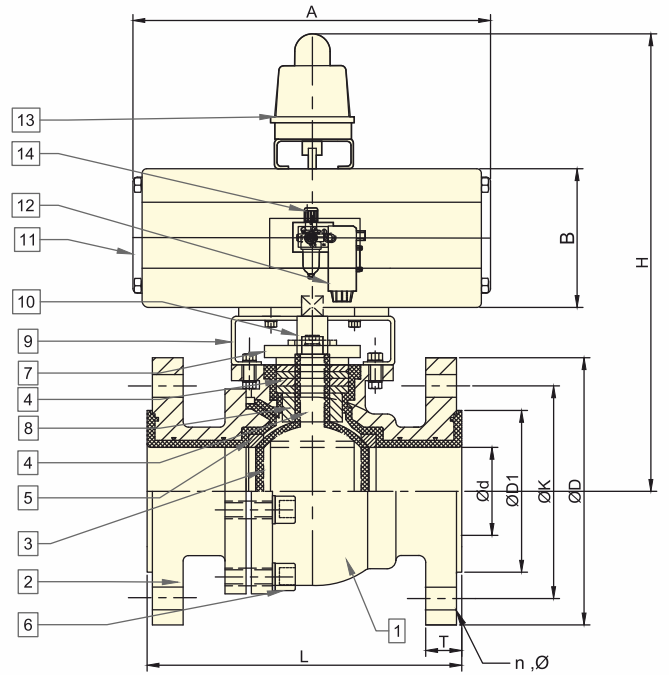

BALL VALVE (CONTROL)



SECTIONAL VIEW

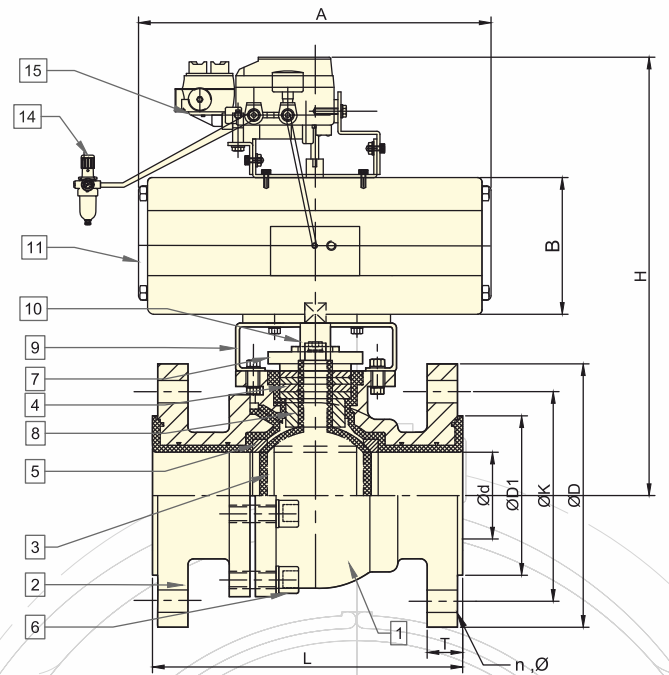

TOP MOUNTING DETAILS

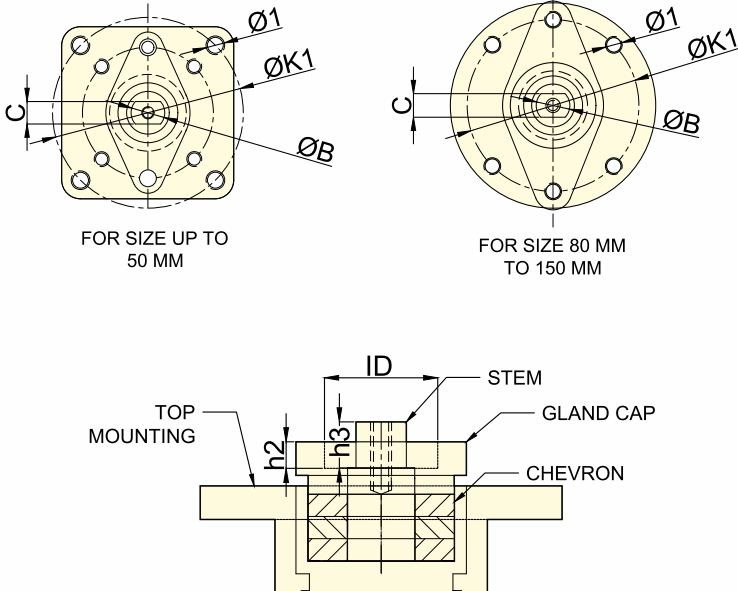

PART LIST

PART NO.	DESCRIPTION	MATERIAL OF CONSTRUCTION	QTY.
1	Body	ASTM A 216 GR.WCB + PFA LINED	1
2	Side Piece	ASTM A 216 GR.WCB + PFA LINED	1
3	Ball Stem Unit	ASTM A 351 GR. CF8 + PFA LINED	1
4	Stem Seal	PTFE V-SHAPE CHEVRON PACKING	3 - 6
5	Seat	PTFE	2
6	Fasteners	ASTM A 193 GR. B7 / SS 304 / SS 316	4 - 8
7	Gland Cover	ASTM A 351 GR. CF8	1
8	Bush	PTFE	1
9	Clamp	SS 304	1
10	Coupler	SS 304	1
11	Actuator	TO CUSTOMER REQUEST	1
12	Solenoid Valve	TO CUSTOMER REQUEST	1
13	Limit Switch	TO CUSTOMER REQUEST	1
14	Air Filter Regulator	TO CUSTOMER REQUEST	1
15	E2P Positioner	TO CUSTOMER REQUEST	1

DIMENSIONS OF ANSI

Size	Ød ± 0.04		L ± 0.12		ØD ± 0.04		EN ISO 5211	ØK1 ± 1.6		Ø1 TAPPING	DOUBLE D ØB X C	h2		h3 HEIGHT		ID (GLAND)		T + 0.11 / - 0.00		ØK ± 0.062		n	Ø	
	INCH	MM	INCH	MM	INCH	MM		INCH	MM			INCH	MM	INCH	MM	INCH	MM	INCH	MM	INCH	MM		INCH	MM
½"	0.51	13	5.12	130	3.74	95	F05	1.97	50.00	M6	Ø12 X 8	0.27	6.80	0.43	11.00	1.06	27.00	0.55	14.00	2.55	65	4	0.55	14
¾"	0.78	20	5.19	150	4.13	105	F05	1.97	50.00	M6	Ø12 X 8	0.41	10.50	0.43	11.00	1.02	26.00	0.55	14.00	2.95	75	4	0.55	14
1"	0.98	25	5.00	127	4.25	108	F07	2.75	70.00	M8	Ø12 X 8	0.41	10.50	0.67	17.00	1.02	26.00	0.67	17.00	3.10	79	4	0.62	16
1½"	1.57	40	6.49	165	5.00	127	F10	4.01	102.00	M8	Ø18 X 12	0.26	6.50	0.39	10.00	1.26	32.00	0.74	19.00	3.85	98	4	0.62	16
2"	1.96	50	7.00	178	5.98	152	F10	4.01	102.00	M10	Ø18 X 12	0.26	6.50	0.51	13.00	1.26	32.00	0.80	20.00	4.76	121	4	0.75	19
2½"	2.55	65	7.48	190	7.00	178	F10	4.01	102.00	M10	Ø20 X 14	0.35	9.00	0.59	15.00	1.61	41.00	0.90	23.00	5.51	140	4	0.75	19
3"	2.95	75	7.99	203	7.51	191	F10	4.01	102.00	M10	Ø20 X 14	0.35	9.00	0.59	15.00	1.61	41.00	0.98	25.00	5.98	152	4	0.75	19
4"	3.93	100	9.01	229	9.00	229	F10	4.01	102.00	M10	Ø20 X 14	0.39	10.00	0.59	15.00	1.61	41.00	0.98	25.00	7.51	191	8	0.75	19
6"	5.90	150	10.51	267	11.02	280	F12	4.92	125.00	M12	Ø38 X 27	0.20	5.00	0.98	25.00	1.97	50.00	1.10	28.00	9.48	241	8	0.86	22

DIMENSIONS OF DIN

Size	Ød ± 0.04		L ± 0.12		ØD ± 0.04		EN ISO 5211	ØK1 ± 1.6		Ø1 TAPPING	DOUBLE D ØB X C	h2		h3 HEIGHT		ID (GLAND)		T + 0.11 / - 0.00		ØK ± 0.062		n	Ø	
	INCH	MM	INCH	MM	INCH	MM		INCH	MM			INCH	MM	INCH	MM	INCH	MM	INCH	MM	INCH	MM		INCH	MM
½"	0.51	13	5.12	130	3.74	95	F05	1.97	50.00	M6	Ø12 X 8	0.27	6.80	0.43	11.00	1.06	27.00	0.55	14.00	2.55	65	4	0.55	14
¾"	0.78	20	5.19	150	4.13	105	F05	1.97	50.00	M6	Ø12 X 8	0.41	10.50	0.43	11.00	1.02	26.00	0.55	14.00	2.95	75	4	0.55	14
1"	0.98	25	6.30	160	4.53	115	F07	2.75	70.00	M8	Ø12 X 8	0.41	10.50	0.67	17.00	1.02	26.00	0.67	17.00	3.35	85	4	0.55	14
1½"	1.57	40	7.87	200	5.91	150	F10	4.01	102.00	M8	Ø18 X 12	0.26	6.50	0.39	10.00	1.26	32.00	0.74	19.00	4.33	110	4	0.70	18
2"	1.96	50	9.06	230	6.50	165	F10	4.01	102.00	M10	Ø18 X 12	0.26	6.50	0.51	13.00	1.26	32.00	0.80	20.00	4.92	125	4	0.70	18
2½"	2.55	65	7.48	190	7.28	185	F10	4.01	102.00	M10	Ø20 X 14	0.35	9.00	0.59	15.00	1.61	41.00	0.90	23.00	5.70	145	4	0.70	18
3"	2.95	75	12.20	310	7.87	200	F10	4.01	102.00	M10	Ø20 X 14	0.35	9.00	0.59	15.00	1.61	41.00	0.98	25.00	6.30	160	8	0.70	18
4"	3.93	100	13.80	350	8.66	220	F10	4.01	102.00	M10	Ø20 X 14	0.39	10.00	0.59	15.00	1.61	41.00	0.98	25.00	7.09	180	8	0.70	18
6"	5.90	150	18.90	480	11.02	280	F12	4.92	125.00	M12	Ø38 X 27	0.20	5.00	0.98	25.00	1.97	50.00	1.10	28.00	9.45	240	8	0.86	22

NOTE: 1. A, B & H DIMENSIONS MAY VARY AS PER ACTUATOR MAKE & MODEL AND WILL BE PROVIDED AS PER CUSTOMER REQUIREMENT
2. TOLERANCES ARE GIVEN IN INCHES

PRODUCT DESIGN AND TESTS PERFORMED

DESIGN PARAMETERS	STANDARD
DESIGN STD	BS EN 17292
SHELL DESIGN	ANSI B 16.34
FLANGE CONNECTION RATING	ANSI B 16.5, 150# / DIN PN 10 / JIS
TESTING STANDARD	API 598 / BS EN 12266-1
CONNECTION	FLANGED, RF

TEST PERFORMED	API 598	API 598
SIZES	½" TO 4"	6" TO 12"
HIGH PR. SHELL TEST HYDRO	420 PSI	225 PSI
HIGH PR. SEAT TEST HYDRO	270 PSI	165 PSI
LOW PR. SEAT PNEUMATIC	105 PSI	75 PSI

SPARK TEST	KVDC
SPARK TEST	20 KVDC

VALVE Cv & TORQUE VALUES

Size		Cv FULL PORT	TORQUE FULL PORT	TORQUE FULL PORT
INCH	MM		NM	in - lbs
½"	15	15	10	88
¾"	20	25	12	106
1"	25	50	12	106
1½"	40	185	20	177
2"	50	320	25	221
3"	80	805	40	354
4"	100	1600	65	575
6"	150	4500	180	1593
8"	200	8300	280	2478
10"	250	11725	350	3098
12"	300	18100	500	4425

TYPE	SIZE	STANDARD FOR END TO END DIM
FULL PORT SIDE SPLIT	1" - 6"	ANSI B 16.1 SHORT PATTERN
FULL PORT CENTRE SPLIT	8" - 12"	ANSI B 16.1 LONG PATTERN
FULL PORT SIDE SPLIT	½" & ¾"	DIN EN 558 SERIES - 1
FULL PORT SIDE SPLIT	½" - 6"	DIN EN 558 SERIES - 1

PRESSURE - TEMPERATURE GRAPH

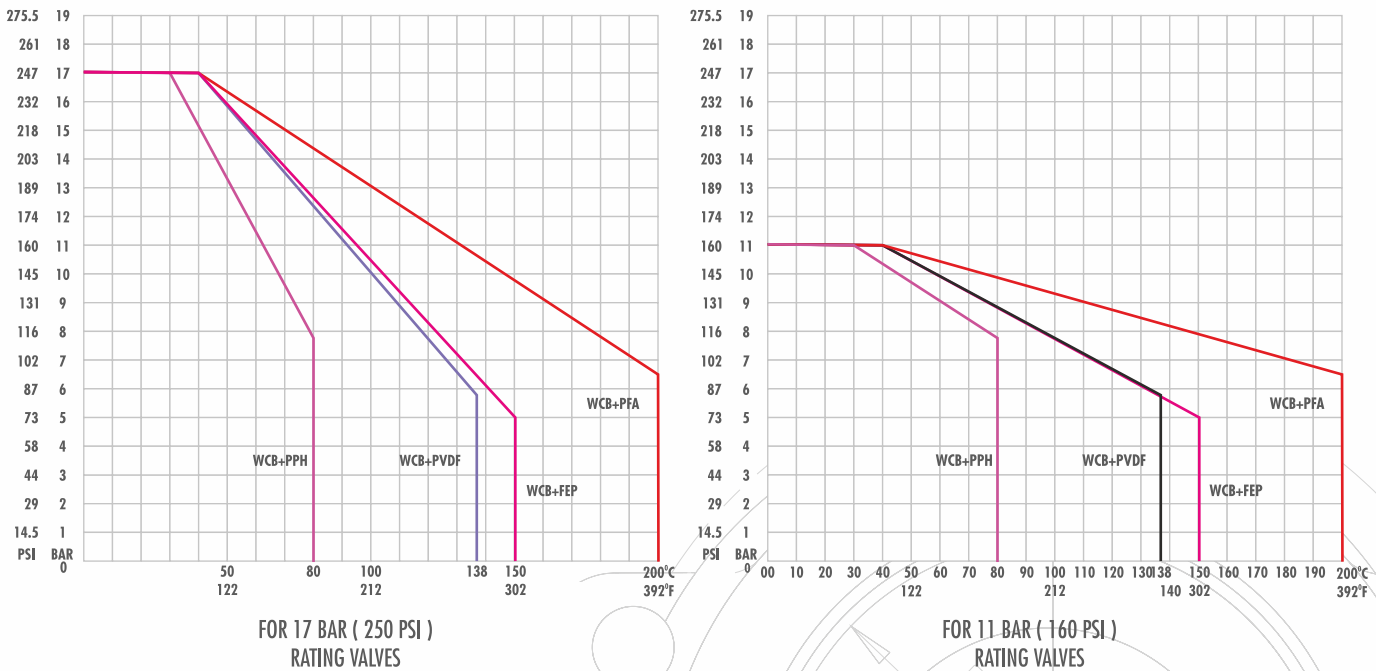

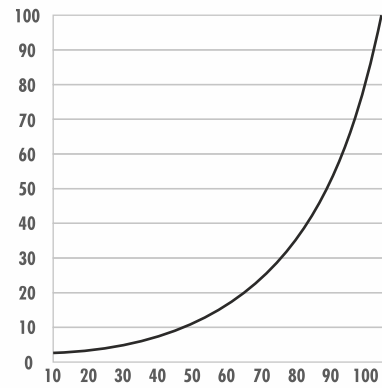

% of Opening

FLOW VALUE CV (%) FOR V-PORT CONTROL VALVE FOR EQUAL PERCENTAGE CHARACTERISTICS

Size NB		V PORT	VALVE OPENING ANGLE								
INCH	MM	DEGREE	10°	20°	30°	40°	50°	60°	70°	80°	90°
½"	15	15°	-	-	-	-	0.04	0.16	0.36	0.65	0.99
		30°	-	-	-	-	0.07	0.32	0.73	1.29	1.95
		45°	-	-	-	-	0.11	0.48	1.08	1.90	2.85
		60°	-	-	-	-	0.16	0.64	1.43	2.47	3.65
		90°	-	-	-	-	0.25	0.98	2.10	3.48	4.91
¾"	20	15°	-	-	-	0.03	0.18	0.45	0.85	1.35	1.94
		30°	-	-	-	0.06	0.36	0.90	1.68	2.67	3.78
		45°	-	-	-	0.10	0.54	1.35	2.50	3.93	5.51
		60°	-	-	-	0.14	0.73	1.80	3.30	5.11	7.06
		90°	-	-	-	0.23	1.15	2.71	4.77	7.13	9.49
1"	25	15°	0.00	0.00	0.03	0.18	0.47	0.91	1.47	2.11	2.85
		30°	0.00	0.00	0.06	0.37	0.95	1.81	2.92	4.17	5.60
		45°	0.00	0.00	0.10	0.56	1.43	2.71	4.33	6.22	8.17
		60°	0.00	0.00	0.14	0.76	1.92	3.59	5.68	8.06	10.47
		90°	0.00	0.00	0.23	1.21	2.94	5.31	8.14	11.17	14.08
1½"	40	15°	0.00	0.00	0.16	0.61	1.37	2.45	3.81	5.40	7.12
		30°	0.00	0.01	0.33	1.22	2.74	4.88	7.55	10.61	13.78
		45°	0.00	0.01	0.51	1.86	4.13	7.28	11.18	15.58	20.10
		60°	0.00	0.01	0.70	2.52	5.53	9.64	14.64	20.18	25.76
		90°	0.00	0.03	1.14	3.96	8.40	11.50	20.88	27.94	34.61
2"	50	15°	0.00	0.06	0.50	1.44	2.93	4.96	7.44	10.23	13.12
		30°	0.00	0.12	1.01	2.91	5.87	9.88	14.75	20.20	25.80
		45°	0.00	0.19	1.55	4.40	8.83	14.72	21.81	29.66	37.61
		60°	0.00	0.27	2.12	5.95	11.79	19.46	28.52	38.38	48.21
		90°	0.00	0.45	3.42	9.27	17.80	28.48	40.55	53.04	64.78
3"	80	15°	0.00	0.27	1.43	3.68	7.50	11.63	17.10	23.20	29.83
		30°	0.00	0.55	2.89	7.40	15.00	24.38	33.91	45.81	58.65
		45°	0.00	0.84	4.41	11.19	22.50	34.50	50.13	67.25	85.51
		60°	0.00	1.17	6.02	15.10	30.00	45.57	65.53	87.05	109.62
		90°	0.00	1.95	9.66	23.44	45.00	66.58	93.10	120.33	147.30
4"	100	15°	0.00	0.39	2.36	6.11	11.82	19.42	28.58	38.81	49.72
		30°	0.00	0.79	4.77	12.28	23.66	38.67	56.67	76.62	97.75
		45°	0.00	1.21	7.27	18.58	35.51	57.60	83.78	112.48	142.52
		60°	0.00	1.67	9.92	25.08	47.40	76.07	109.52	145.58	182.70
		90°	0.00	2.80	15.94	38.94	71.31	111.13	155.54	201.15	245.49
6"	150	15°	0.00	1.50	6.42	15.42	28.75	46.17	66.94	89.89	114.35
		30°	0.00	3.04	12.96	30.99	57.50	91.91	132.68	177.43	224.82
		45°	0.00	4.66	19.74	46.84	86.25	136.83	196.09	272.96	327.80
		60°	0.01	6.43	26.89	63.12	115.00	180.56	256.17	336.97	420.21
		90°	0.01	10.75	43.13	97.80	172.72	263.18	363.28	465.28	564.63

BUTTERFLY ON-OFF & CONTROL VALVE

BUTTERFLY VALVE (ON-OFF & CONTROL) (LUG TYPE)



SECTIONAL VIEW

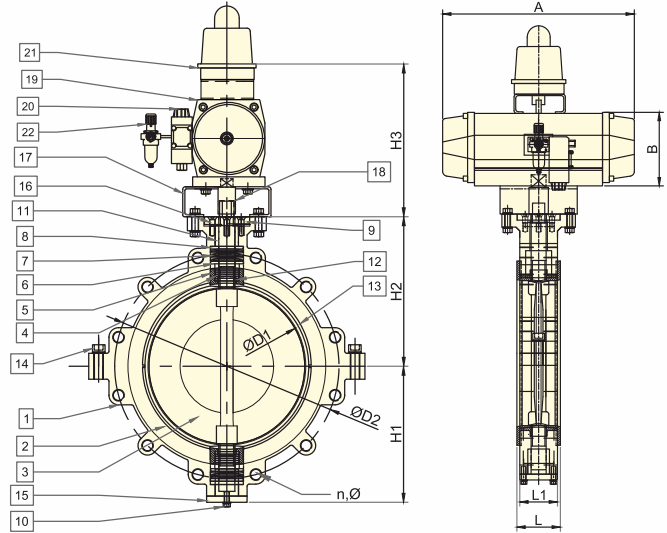

BUTTERFLY VALVE (ON-OFF & CONTROL) (WAFER TYPE)



SECTIONAL VIEW

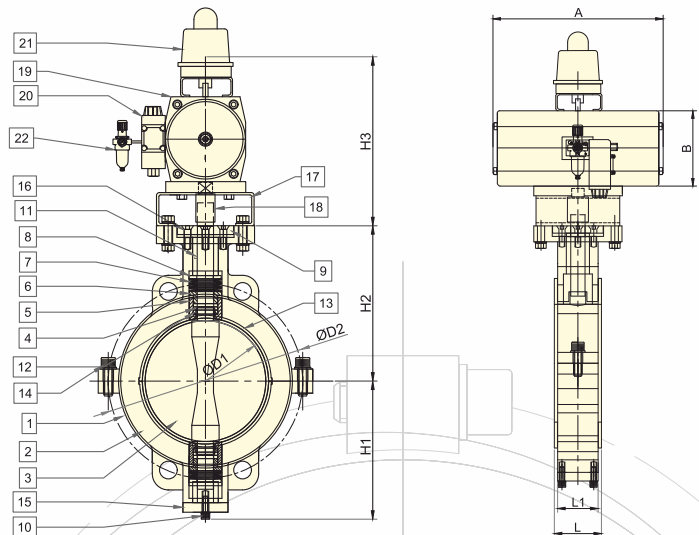

SECTIONAL VIEW

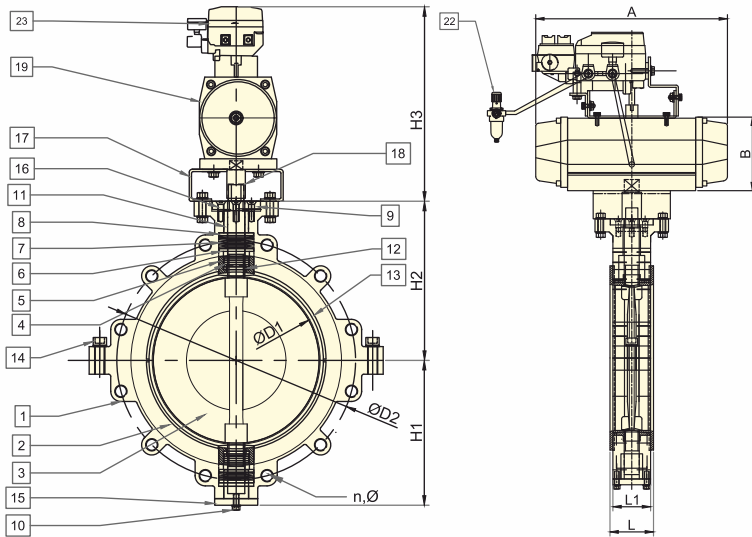

PART LIST

PART NO.	DESCRIPTION	MATERIAL OF CONSTRUCTION	QTY.
1	Body	ASTM A 216 GR. WCB	2
2	Seat	PTFE / TFM	1
3	Disc & Stem Unit	ASTM A 890 GR. A4 (CD3MN) + PFA LINED	1
4	Stem Seal (Top + Bottom)	VITON	02 + 02
5	Seal Cup (Top + Bottom)	PFA	01 + 01
6	T Bush (Top + Bottom)	SS 304	01 + 01
7	Disc Spring (Top + Bottom)	50 Crv 4	06 + 04
8	Retainer (Top + Bottom)	SS 304	01 + 01
9	Thrust Collar - Top	SS 304	1
10	Bottom Cover Bolt	HT STEEL	2
11	Sleeve	SS 304	1
12	Washer (Top + Bottom)	PTFE	01 + 01
13	Seat Pad (Top + Bottom)	VITON / SILICON	01 + 01
14	Body Bolts	ASTM A 193 GR.B7	2
15	Thrust Collar - Bottom	SS 304	1
16	Top Thrust Collar Screw	HT STEEL	4
17	Clamp	SS 304	1
18	Coupler	SS 304	1
19	Actuator	TO CUSTOMER REQUEST	1
20	Solenoid Valve	TO CUSTOMER REQUEST	1
21	Limit Switch	TO CUSTOMER REQUEST	1
22	Air Filter Regulator	TO CUSTOMER REQUEST	1
23	E2P Positioner	TO CUSTOMER REQUEST	1

SECTIONAL VIEW

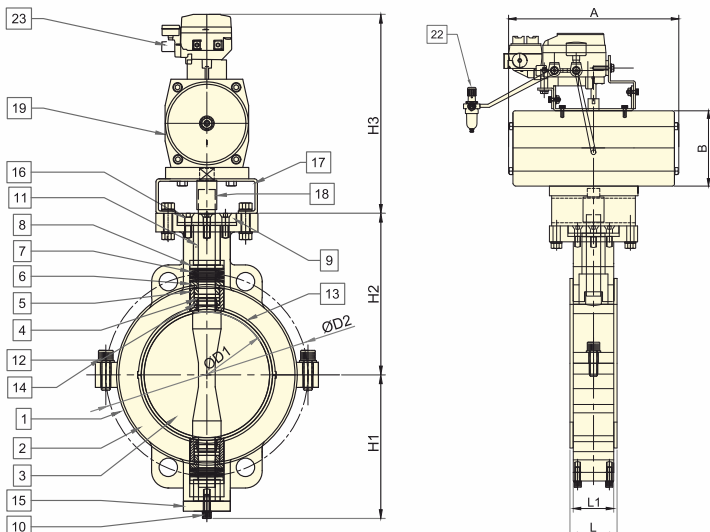

TOP MOUNTING DETAILS

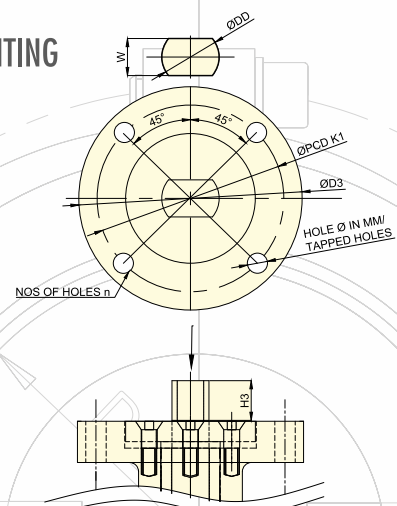

DIMENSIONS (LUG TYPE)

Size	L ±0.12		L1 ±0.4		Ød1 ±0.8		Ød2 ±0.8		ØD3		EN ISO 5211	PCD K1	NO OF HOLES (n)		HOLE DIA	DOUBLE D DD	W		H3 STEM HEIGHT		H1 ±0.31		H2 ±0.31	
	INCH	MM	INCH	MM	INCH	MM	INCH	MM	INCH	MM			MM	ANSI			DIN	MM	MM	INCH	MM	INCH	MM	INCH
2"	1.85	47	1.69	43	1.97	60	4.76	121	3.54	90	F07	70	4	4	8	14	0.43	11	0.98	25	3.27	83	4.60	117
2½"	1.97	50	1.81	46	2.55	65	5.51	140	3.54	90	F07	70	4	4	8	14	0.43	11	0.98	25	3.54	90	5.39	137
3"	1.97	50	1.81	46	2.95	75	6.00	152	3.54	90	F07	70	4	8	8	14	0.43	11	0.98	25	3.54	90	5.04	128
4"	2.20	56	2.04	52	3.93	100	7.50	191	3.54	90	F07	70	8	8	8	18	0.55	14	0.98	25	4.52	115	6.14	156
5"	2.36	60	2.20	56	4.92	125	8.50	216	4.92	125	F10	102	8	8	10.50	2	0.55	14	0.98	25	6.37	162	7.63	194
6"	2.36	60	2.20	56	5.90	150	9.49	241	4.92	125	F10	102	8	8	10.50	20	0.55	14	0.98	25	7.20	183	9.25	235
8"	2.52	64	2.36	60	7.87	200	11.75	298	4.92	125	F10	102	8	8	10.50	25	0.75	19	0.98	25	9.21	234	9.88	251
10"	2.83	72	2.68	68	9.84	250	14.25	362	5.98	152	F12	125	12	12	12.5	28	0.87	22	1.18	30	10.66	271	11.57	294
12"	3.30	84	3.07	78	11.81	300	17.00	432	5.98	152	F12	125	12	12	12.5	28	0.87	22	1.18	30	12.20	310	12.79	325
14"	3.30	84	3.07	78	13.78	350	18.70	476	5.98	152	F12	125	12	16	12.5	28	0.87	22	1.18	30	13.18	335	13.58	345
16"	4.25	108	4.01	102	15.74	400	21.25	540	7.08	180	F14	140	16	16	17	36	1.10	28	1.77	45	15.55	395	14.76	375
18"	4.72	120	4.49	114	17.71	450	22.75	578	7.08	180	F14	140	16	20	17	36	1.10	28	177.00	45	15.75	400	15.35	390
20"	5.23	133	5.00	127	19.44	495	25.00	635	8.27	210	F16	165	20	20	22	46	1.42	36	1.77	45	16.73	425	16.33	415
24"	6.29	160	6.06	154	23.54	600	29.52	749	9.45	240	F20	200	20	20	20	51	1.65	42	1.77	45	18.70	475	19.48	495

DIMENSIONS (WAFER TYPE)

Size	L ±0.12		L1 ±0.4		Ød1 ±0.8		Ød2 ±0.8		ØD3		EN ISO 5211	PCD K1	NO OF HOLES (n)	HOLE DIA	DOUBLE D DD	W		H3 STEM HEIGHT		H1 ±0.31		H2 ±0.31	
	INCH	MM	INCH	MM	INCH	MM	INCH	MM	INCH	MM						MM	MM	INCH	MM	INCH	MM	INCH	MM
2"	1.85	47	1.69	43	1.97	60	4.76	121	3.54	90	F07	70	4	8	14	0.43	11	0.98	25	3.27	83	4.60	117
2½"	1.97	50	1.81	46	2.55	65	5.51	140	3.54	90	F07	70	4	8	14	0.43	11	0.98	25	3.54	90	5.39	137
3"	1.97	50	1.81	46	2.95	75	6.00	152	3.54	90	F07	70	4	8	14	0.43	11	0.98	25	3.54	90	5.04	128
4"	2.20	56	2.04	52	3.93	100	7.50	191	3.54	90	F07	70	4	8	18	0.55	14	0.98	25	4.52	115	6.14	156
5"	2.36	60	2.20	56	4.92	125	8.50	216	4.92	125	F10	102	4	10.5	2	0.55	14	0.98	25	6.37	162	7.63	194
6"	2.36	60	2.20	56	5.90	150	9.49	241	4.92	125	F10	102	4	10.5	20	0.55	14	0.98	25	7.20	183	9.25	235
8"	2.52	64	2.36	60	7.87	200	11.75	298	4.92	125	F10	102	4	10.5	25	0.75	19	0.98	25	9.21	234	9.88	251
10"	2.83	72	2.68	68	9.84	250	14.25	362	5.98	152	F12	125	4	12.5	28	0.87	22	1.18	30	10.66	271	11.57	294
12"	3.30	84	3.07	78	11.81	300	17.00	432	5.98	152	F12	125	4	12.5	28	0.87	22	1.18	30	12.20	310	12.79	325
14"	3.30	84	3.07	78	13.78	350	18.70	476	5.98	152	F12	125	4	12.5	28	0.87	22	1.18	30	13.18	335	13.58	345
16"	4.25	108	4.01	102	15.74	400	21.25	540	7.08	180	F14	140	4	17	36	1.10	28	1.77	45	15.55	395	14.76	375
18"	4.72	120	4.49	114	17.71	450	22.75	578	7.08	180	F14	140	4	17	36	1.10	28	177.00	45	15.75	400	15.35	390
20"	5.23	133	5.00	127	19.44	495	25.00	635	8.27	210	F16	165	4	22	46	1.42	36	1.77	45	16.73	425	16.33	415
24"	6.29	160	6.06	154	23.54	600	29.52	749	9.45	240	F20	200	4	20	51	1.65	42	1.77	45	18.70	475	19.48	495

Note : 1. A, B & H3 Dimensions may vary as per actuator make & model and will be provided as per customer requirement
 2. Tolerances are given in inches

PRODUCT DESIGN AND TESTS PERFORMED

DESIGN PARAMETERS	STANDARD	TEST PERFORMED	API 598
DESIGN STD	API 609	SIZES	2" To 24"
FACE TO FACE DIMENSION	API 609 CATEGORY A	HIGH PR. SHELL TEST HYDRO	225 PSI (15 kg/cm ²)
FLANGE CONNECTION RATING	ANSI B 16.5, 150#	HIGH PR. SEAT TEST HYDRO	165 PSI (11 kg/cm ²)
TESTING STANDARD	API 598 / BS EN 12266-1	LOW PR. SEAT PNEUMATIC	75 PSI (05 kg/cm ²)
TEMPERATURE	-40 TO 450 F (PFA)		

SPARK TEST **KVDC**

SPARK TEST 20 KVDC

VALVE TORQUE VALUE

Size		TORQUE FULL PORT	TORQUE FULL PORT
INCH	MM	NM	in - lbs
2"	50	30	265
2½"	65	30	265
3"	80	30	265
4"	100	60	530
5"	125	110	972
6"	150	125	1105
8"	200	180	1591
10"	250	360	3183
12"	300	480	4243
14"	350	800	7072
16"	400	1200	1608
18"	450	2018	17840
20"	500	2460	21746
24"	600	3075	27183

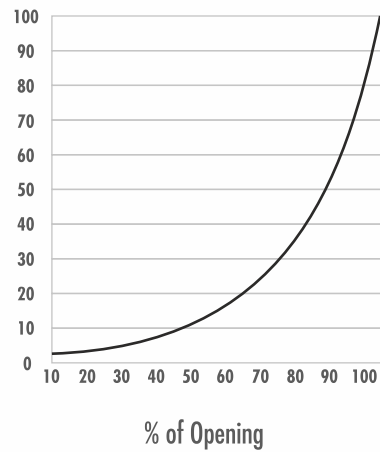

PRESSURE - TEMPERATURE GRAPH FOR WCB + PFA/PTFE BUTTERFLY VALVE

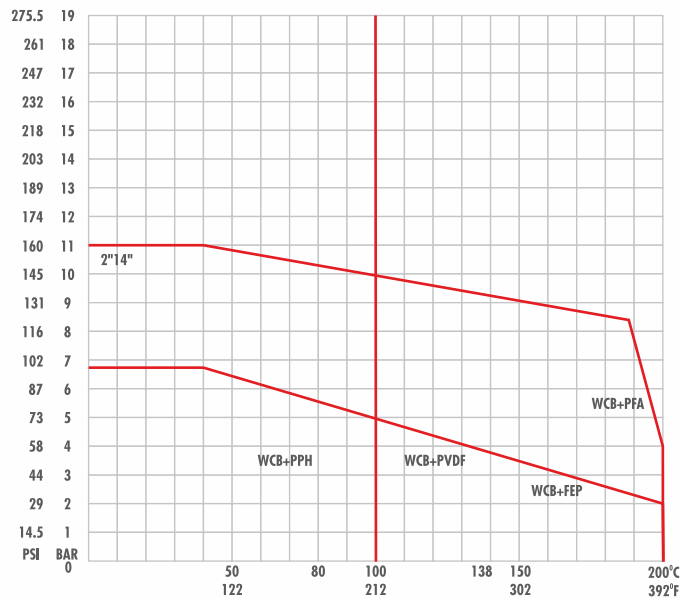

FOR 17 BAR (250 PSI) RATING VALVES

Cv VALUES FOR BUTTERFLY VALVE AT DIFFERENT POSITIONS

Size NB		20°	30°	40°	50°	60°	70°	80°	90°
INCH	MM								
2"	50	5.8	13	28	49	74	107	137	155
2½"	65	9.3	22	47	81	125	180	232	263
3"	80	17	38	83	145	220	313	388	455
4"	100	23	56	110	188	296	447	563	678
5"	125	44	95	191	296	528	748	945	1177
6"	150	70	151	273	458	748	1108	1415	1734
8"	200	110	267	539	922	1369	215	2796	3538
10"	250	203	406	824	1346	1867	2807	4234	5232
12"	300	307	605	1154	1995	3091	4599	6914	8363
14"	350	406	765	1369	2088	3341	5278	8329	10161
16"	400	591	1142	1717	2842	4907	7598	10730	13166
18"	450	771	1456	2587	4466	7250	10672	14210	17284
20"	500	1032	1879	3456	6206	9454	13688	18050	20880
24"	600	1125	2494	4849	8607	13166	19082	24592	28420

PLUG ON-OFF & CONTROL VALVE

PLUG VALVE (ON-OFF)



SECTIONAL VIEW

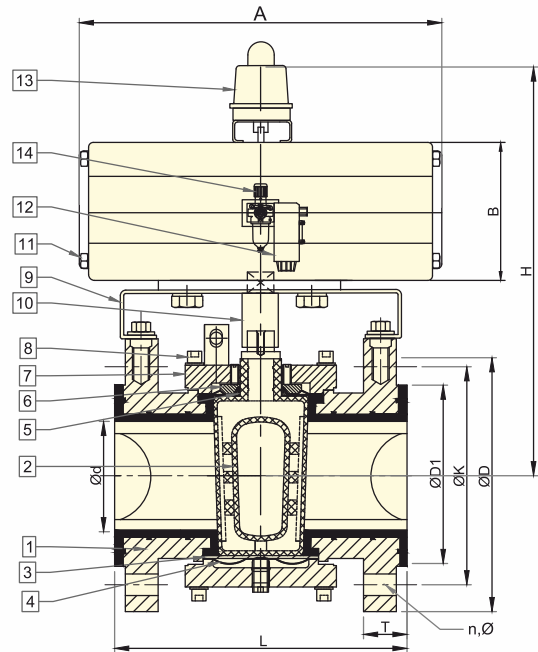

PLUG VALVE (CONTROL)



SECTIONAL VIEW

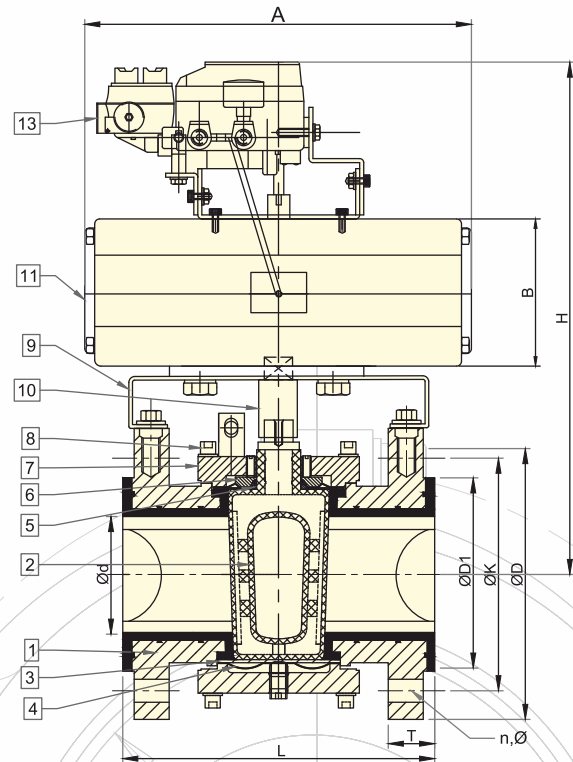

TOP MOUNTING DETAILS

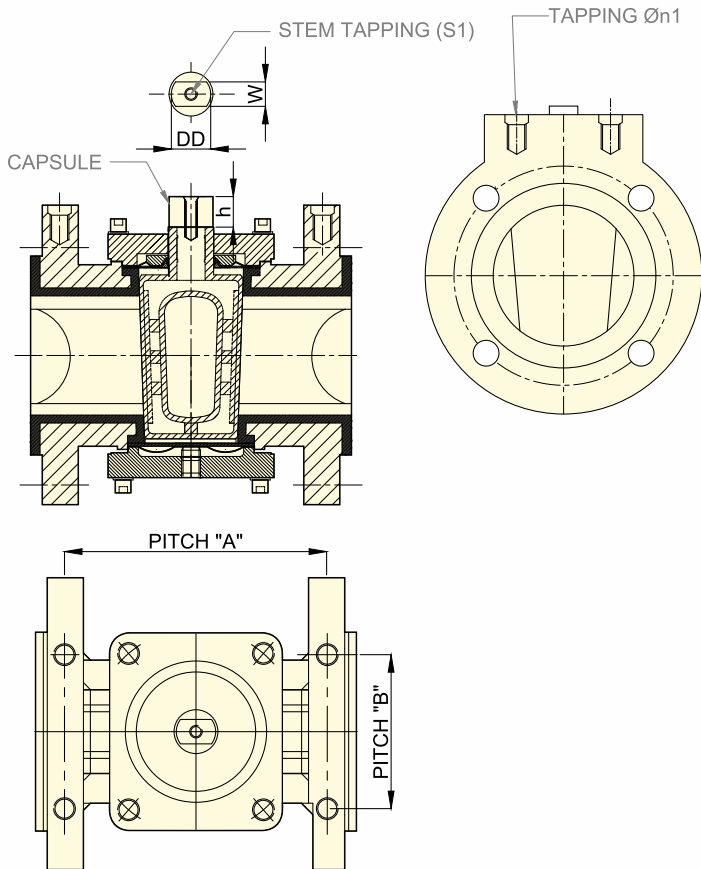

PART LIST

PART NO.	DESCRIPTION	MATERIAL OF CONSTRUCTION	QTY.
1	Body	ASTM A 216 GR. WCB + PFA LINED	1
2	Plug	ASTM A 890 GR. 4A (CD3MN) + PFA OR TEFCOR LINED	1
3	Diaphragm (Top & Bottom)	PTFE	2
4	Shim (Top & Bottom)	SS 304	2
5	Wedge Ring	PTFE	1
6	Thrust Collar	SS 304	1
7	Cover Plate (Top & Bottom)	ASTM A 216 GR. WCB	2
8	Fasteners (Top & Bottom)	ASTM A 193 GR. B7	8
9	Clamp	SS 304	1
10	Coupler	SS 304	1
11	Actuator	TO CUSTOMER REQUEST	1
12	Solenoid Valve	TO CUSTOMER REQUEST	1
13	E2P Positioner	TO CUSTOMER REQUEST	1
14	Air Filter Regulator	TO CUSTOMER REQUEST	1

DIMENSIONS

Size	Ød ±0.04		L ±0.12		ØD ±0.04		ØD1 ±0.04		ØK ±0.062		PITCH "A"		PITCH "B"		DOUBLE D DD X W	h HEIGHT		T +0.11/-0.00		n	Ø		FLANGE TAPPING Øn1	STEM TAPPING ØS1
	INCH	MM	INCH	MM	INCH	MM	INCH	MM	INCH	MM	INCH	MM	INCH	MM		INCH	MM	INCH	MM		INCH	MM		
½"	0.59	15	4.25	108	3.50	89	1.38	35	2.36	60	3.62	92	1.37	35	Ø12.8 X 8	3.80	8.00	0.51	13	4	0.63	16	M6 X 12MM	M5 X 12MM
1"	0.98	25	5.00	127	4.25	108	2.00	51	3.11	79	4.33	110	1.57	40	Ø15.8 X 11	0.22	12.00	0.63	16	4	0.63	16	M6 X 20MM	M6 X 20MM
1½"	1.50	39	6.49	165	5.00	127	2.87	73	3.86	98	5.59	142	1.57	40	Ø15.8 X 11	0.35	15.00	0.74	19	4	0.63	16	M6 X 20MM	M6 X 20MM
2"	1.97	50	7.00	178	5.98	152	3.62	92	4.76	121	5.90	150	1.96	50	Ø25 X 16	0.31	15.00	0.80	21	4	0.75	19	M8 X 20MM	M8 X 20MM
3"	2.95	75	7.99	203	7.48	190	5.00	127	5.98	152	6.69	170	2.75	70	Ø27.1 X 18.8	0.35	15.00	0.98	25	4	0.75	19	M8 X 20MM	M10 X 25MM
4"	3.70	94	9.01	229	9.01	229	6.18	157	7.52	191	7.75	197	3.14	80	Ø30.8 X 19	0.33	18.00	0.98	25	8	0.75	19	M10 X 15MM	M10 X 25MM
6"	5.90	150	10.51	267	11.00	280	8.50	216	8.50	216	9.21	234	3.93	100	Ø40 X 25	1.18	19.00	1.10	28	8	0.87	22	M12 X 15MM	M12 X 25MM
8"	7.60	194	11.69	297	13.50	343	10.55	268	10.55	268	10.10	257	4.43	110	Ø40 X 32	1.22	26.50	1.18	30	8	0.87	22	M12 X 20MM	M16 X 30MM

NOTE: 1. A, B & H DIMENSIONS MAY VARY AS PER ACTUATOR MAKE & MODEL AND WILL BE PROVIDED AS PER CUSTOMER REQUIREMENT
2. TOLERANCES ARE GIVEN IN INCHES

PRODUCT DESIGN AND TESTS PERFORMED

DESIGN PARAMETERS	STANDARD
DESIGN STD	API 599
SHELL DESIGN	ANSI B 16.34
FACE TO FACE DIM.	ANSI B 16.10
FLANGE CONNECTION RATING	ANSI B 16.5, 150# / DIN PN 10 / JIS
TESTING STANDARD	BS EN 12266-1
CONNECTION	FLANGED, RF

TEST PERFORMED	API 598
SIZES	½" TO 4"
HIGH PR. SHELL TEST HYDRO	225 PSI (15 kg/cm ²)
HIGH PR. SEAT TEST HYDRO	165 PSI (11 kg/cm ²)
LOW PR. SEAT PNEUMATIC	85 PSI (6 kg/cm ²)

SPARK TEST	KVDC
SPARK TEST	20 KVDC

VALVE Cv & TORQUE VALUES

Size		Cv FULL PORT	TORQUE FULL PORT	TORQUE FULL PORT
INCH	MM		MM	INCH-LBS
½"	15	15	25	221
1"	25	41	35	310
1½"	40	91	50	443
2"	50	169	75	664
3"	80	297	140	1239
4"	100	539	235	2080
6"	150	1123	525	4646
8"	200	1591	1300	11505

PRESSURE - TEMPERATURE GRAPH

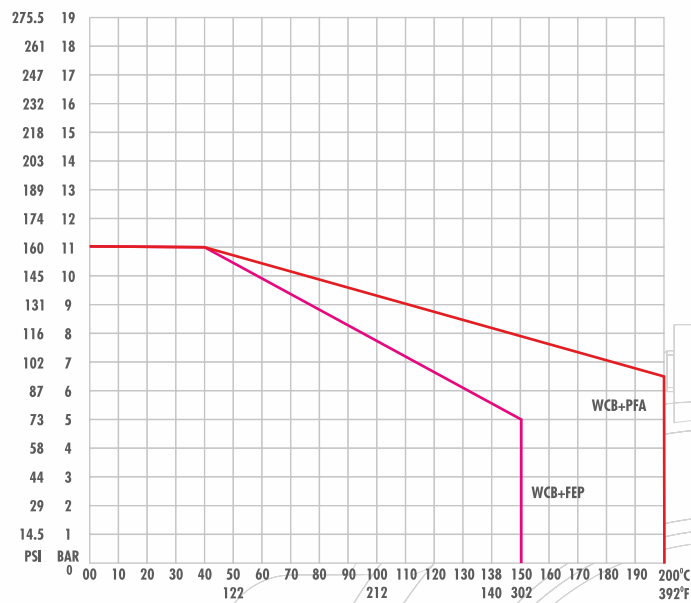

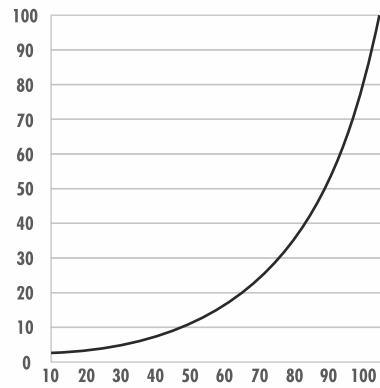

% of Opening

Flow Value Cv (%) for Equal Percentage Characteristics

Size NB		V PORT	VALVE OPENING ANGLE												
INCH	MM	DEGREE	35°	40°	45°	50°	55°	60°	65°	70°	75°	80°	85°	90°	
1"	25	15°	-	-	-	-	-	0.01	0.05	0.11	0.20	0.31	0.42	0.56	
		30°	-	-	-	-	-	0.02	0.09	0.22	0.40	0.63	0.85	1.01	
		45°	-	-	-	-	-	0.03	0.14	0.34	0.62	0.97	1.31	1.76	
		60°	-	-	-	-	-	0.05	0.20	0.47	0.86	1.36	1.83	2.46	
		90°	-	-	-	-	-	0.08	0.35	0.82	1.49	2.35	3.16	4.24	
1½"	40	15°	-	-	-	0.01	0.05	0.13	0.26	0.43	0.64	0.89	1.17	1.42	
		30°	-	-	-	0.01	0.10	0.27	0.53	0.87	1.30	1.80	2.38	2.89	
		45°	-	-	-	0.02	0.15	0.42	0.81	1.34	2.01	2.79	3.68	4.47	
		60°	-	-	-	0.03	0.41	0.58	1.14	1.88	2.80	3.90	5.15	6.25	
		90°	-	-	-	0.05	0.37	1.01	1.97	3.25	4.85	6.74	8.90	10.73	
2"	50	15°	-	-	0.01	0.09	0.24	0.47	0.77	1.16	1.62	2.14	2.73	3.37	
		30°	-	-	0.02	0.20	0.48	0.95	1.57	2.35	3.29	4.35	5.55	6.86	
		45°	-	-	0.04	0.28	0.75	1.47	2.43	3.64	5.08	6.72	8.59	10.61	
		60°	-	-	0.05	0.39	1.05	2.05	3.40	5.09	7.11	9.40	12.01	14.84	
		90°	-	-	0.09	0.67	1.81	3.54	5.87	9.90	12.28	16.24	20.75	25.10	
3"	80	15°	0.01	0.10	0.27	0.54	1.00	1.48	2.07	2.75	3.52	4.36	5.26	6.20	
		30°	0.02	0.20	0.55	1.10	2.03	3.02	4.22	5.60	7.16	8.87	10.70	12.62	
		45°	0.04	0.31	0.85	1.70	3.13	4.67	6.52	8.66	11.07	13.71	16.54	19.51	
		60°	0.05	0.43	1.19	2.38	4.38	6.54	9.12	12.12	15.49	19.18	23.14	27.29	
		90°	0.09	0.74	2.06	4.11	7.57	11.29	15.76	20.94	26.76	33.14	39.98	46.79	
4"	100	15°	0.13	0.36	0.73	1.23	1.88	2.66	3.58	4.62	5.78	7.01	8.35	9.74	
		30°	0.26	0.74	1.49	2.51	3.82	5.42	7.29	9.41	11.77	14.26	17.01	19.82	
		45°	0.41	1.15	2.30	3.88	5.91	8.38	11.27	14.55	18.19	22.05	26.29	30.64	
		60°	0.57	1.60	3.21	5.43	8.27	11.72	15.76	20.36	25.44	30.85	36.77	42.85	
		90°	0.98	2.77	5.55	9.38	14.28	20.25	27.23	35.17	43.96	53.30	63.53	73.54	
6"	150	15°	0.10	0.44	1.03	1.89	3.04	4.47	6.17	8.13	10.31	12.70	15.25	17.39	
		30°	0.20	0.89	2.09	3.86	6.19	9.10	12.56	16.54	21.00	25.86	31.04	35.39	
		45°	0.32	1.37	3.24	5.96	9.57	14.06	1.93	25.57	32.46	39.97	47.99	54.72	
		60°	0.44	1.92	4.53	8.34	13.38	19.67	27.15	35.76	45.40	55.91	67.12	76.53	
		90°	0.76	3.31	7.82	14.40	23.12	33.98	46.91	61.79	78.44	96.60	115.98	132.23	
8"	200	15°	0.13	0.54	1.27	2.32	3.73	5.48	7.55	9.94	12.61	15.53	18.79	21.92	
		30°	0.26	1.10	2.58	4.73	7.58	11.15	15.36	20.23	25.67	31.62	38.24	44.62	
		45°	0.40	1.70	3.99	7.32	11.72	17.24	23.74	31.27	39.69	48.88	59.12	68.98	
		60°	0.56	2.38	5.58	10.23	16.40	24.12	33.21	43.74	55.51	68.37	82.69	96.48	
		90°	0.98	4.12	9.64	17.68	28.33	41.67	57.38	75.57	95.92	118.14	142.88	166.70	

DIAPHRAGM ON-OFF & CONTROL VALVE

DIAPHRAGM VALVE (ON-OFF)



SECTIONAL VIEW

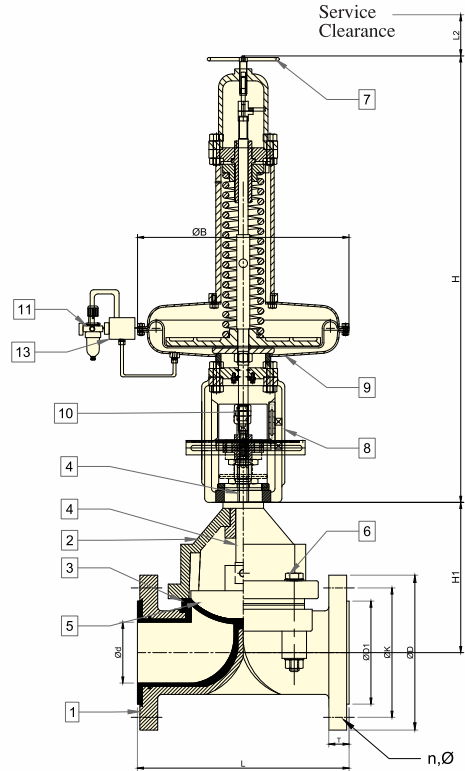

DIAPHRAGM VALVE (CONTROL)



SECTIONAL VIEW

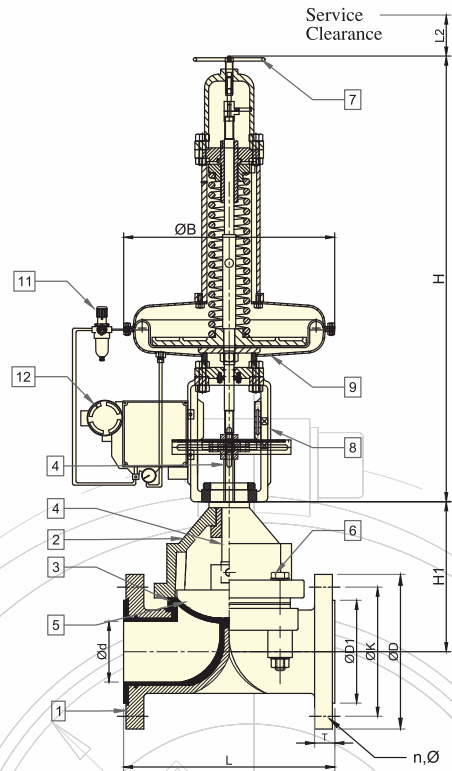

PART LIST

PART NO.	DESCRIPTION	MATERIAL OF CONSTRUCTION	QTY.
1	Body	ASTM A 216 GR. WCB + PFA LINED	1
2	Bonnet	CS EPOXY PAINTED	1
3	Diaphragm	PTFE BACKED WITH EPDM	1
4	Sleeve & Spindle	SS 304	1
5	Compressor	CAST IRON	1
6	Fastners	ASTM A 193 GR. B7	08 - 14
7	Hand Wheel Assembly	CAST IRON	1
8	Yoke	CAST IRON	1
9	Actuator	TO CUSTOMER REQUEST	1
10	Limit Switch	TO CUSTOMER REQUEST	1
11	Air Filter Regulator	TO CUSTOMER REQUEST	1
12	E2P Positioner	TO CUSTOMER REQUEST	1
13	Solenoid Valve	TO CUSTOMER REQUEST	1

DIMENSIONS

Size	ØD ±0.12		L ±0.12		ØD ±0.04		ØK1 ±0.04		ØK ±0.062		T +0.11/-0.00		L1		n	Ø		H1 ±5		H (APPROX)	
	INCH	MM	INCH	MM	INCH	MM	INCH	MM	INCH	MM	INCH	MM	INCH	MM		NOS	INCH	MM	INCH	MM	INCH
½"	0.59	15	4.49	114	3.50	89	1.37	35	2.36	60	0.51	13	7.87	200	4	0.63	16	2.76	70	30.90	785
¾"	0.78	20	4.88	124	3.85	98	1.69	43	2.75	70	0.59	15	7.87	200	4	0.63	16	2.76	70	30.90	785
1"	0.98	25	5.23	133	4.25	108	2.00	51	3.11	79	0.63	16	7.87	200	4	0.63	16	2.76	70	30.90	785
1½"	1.57	40	6.53	166	5.00	127	2.87	73	3.86	98	0.75	19	7.87	200	4	0.63	16	3.54	90	30.90	785
2"	1.96	50	7.71	196	5.98	152	3.62	92	4.76	121	0.82	21	7.87	200	4	0.75	19	5.12	130	30.90	785
2½"	2.55	65	8.74	222	7.00	178	4.13	105	5.51	140	0.90	23	9.85	250	4	0.75	19	5.51	140	32.48	825
3"	2.95	75	10.23	260	7.51	191	5.00	127	5.98	152	0.98	25	9.85	250	4	0.75	19	7.09	180	32.48	825
4"	3.93	100	12.24	311	9.00	229	6.18	157	7.51	191	0.98	25	9.85	250	8	0.75	19	9.05	230	34.84	885
6"	5.90	150	16.22	412	11.02	280	8.50	216	9.49	241	1.06	27	11.81	300	8	0.87	22	11.02	380	45.67	1160
8"	7.87	200	20.74	527	13.50	343	10.62	270	11.73	298	1.18	30	11.81	300	8	0.87	22	15.95	405	48.00	1220
10"	9.84	250	25.27	642	15.98	406	12.76	324	14.25	362	1.30	33	13.78	350	12	0.98	25	16.70	424	48.00	1220

- NOTE :** 1. Actuator can be provided with manual hand wheel on customer request
 2. Tolerances are given in inches

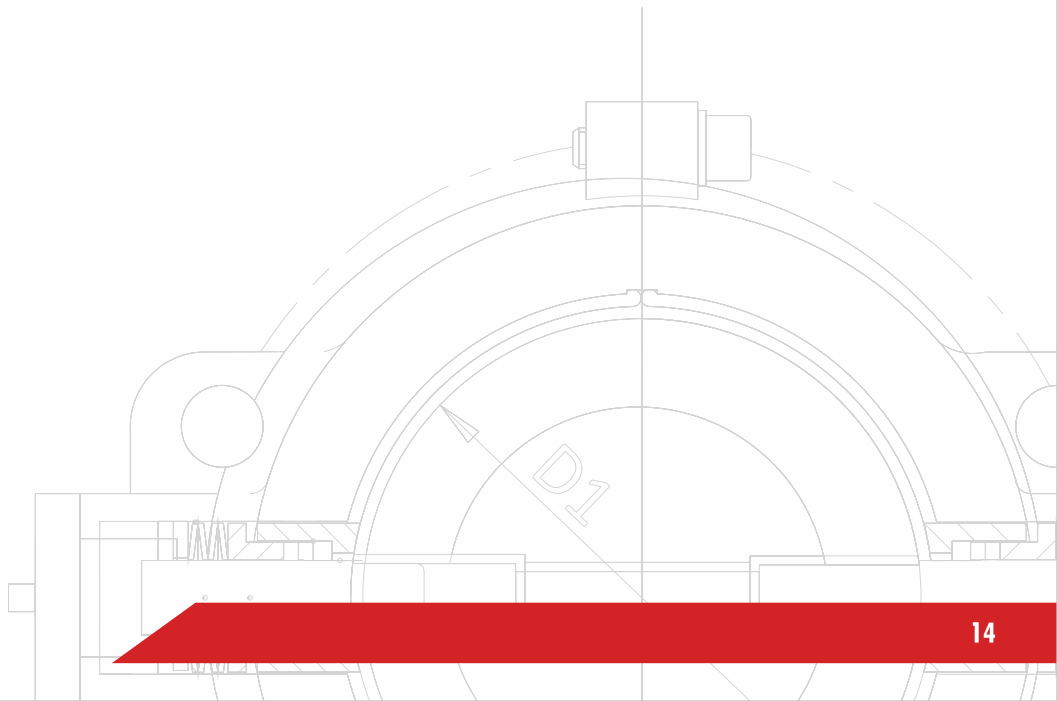

PRODUCT DESIGN AND TESTS PERFORMED

DESIGN PARAMETERS	STANDARD	
DESIGN STD	BS EN 13397	
SHELL DESIGN	ANSI B 16.34	
FACE TO FACE DIM.	EN 558 SERIES 1	
FLANGE CONNECTION RATING	ANSI B 16.5, 150# / DIN PN 10	
TESTING STANDARD	BS EN 12266-1	
CONNECTION	FLANGED, RF	

TEST PERFORMED	BS EN 12266-1	BS EN 12266-1
SIZES	½" TO 4"	6" TO 10"
HIGH PR. SHELL TEST HYDRO	225 PSI (15 kg/cm ²)	75 PSI (5 kg/cm ²)
HIGH PR. SEAT TEST HYDRO	165 PSI (11 kg/cm ²)	57 PSI (4 kg/cm ²)
LOW PR. SEAT PNEUMATIC	75 PSI (5 kg/cm ²)	42 PSI (3 kg/cm ²)

SPARK TEST	KVDC
SPARK TEST	20 KVDC

VALVE Cv & TORQUE VALUES

Size		Cv FULL PORT	ACTUATOR MODEL	
INCH	MM		PN 3.5	PN 10
½"	15	4.50	UNP 20M LPA	UNP 20M LPA
¾"	20	6.50	UNP 20M LPA	UNP 30M LPA
1"	25	11.50	UNP 20M LPA	UNP 30M LPA
1½"	40	33.00	UNP 30M LPA	UNP 30M LPA
2"	50	60.00	UNP 30M LPA	UNP 40M LPA
2½"	65	85.00	UNP 30M LPA	UNP 40M LPA
3"	80	150.00	UNP 40M LPA	UNP 45M LPA
4"	100	270.00	UNP 45M LPA	UNP 45M LPA
6"	150	500.00	"UNP 55M LPA (AFC) UNP 80M LPA (AFO)"	UNP 80M LPA
8"	200	1275.00	UNP 80M LPA	---
10"	250	1980.00	UNP 80M LPA	---

PRESSURE - TEMPERATURE GRAPH

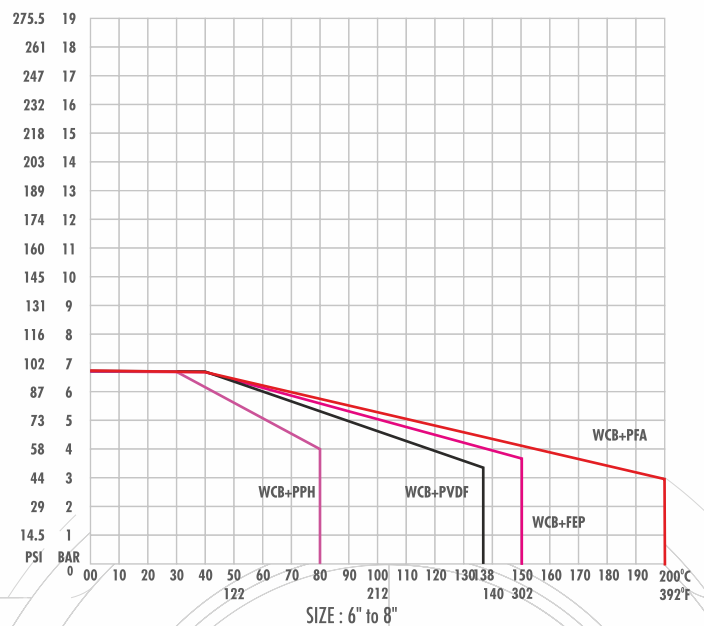
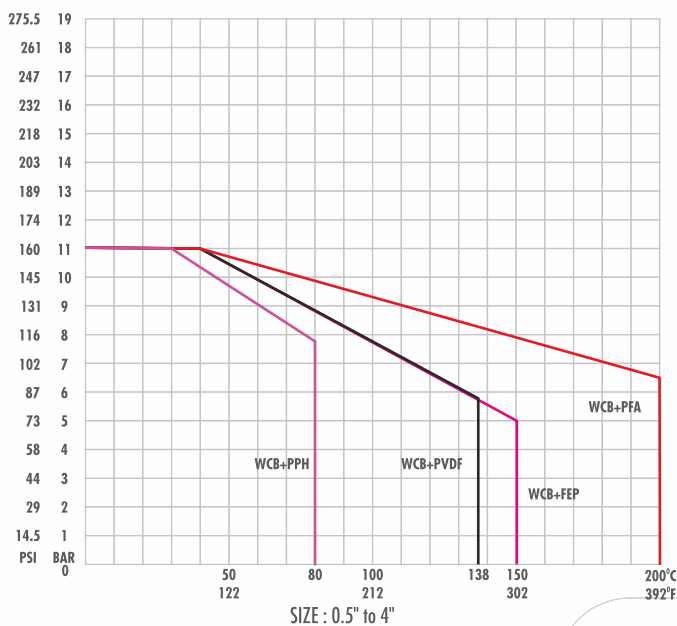

GLOBE CONTROL VALVE

GLOBE CONTROL VALVE



SECTIONAL VIEW

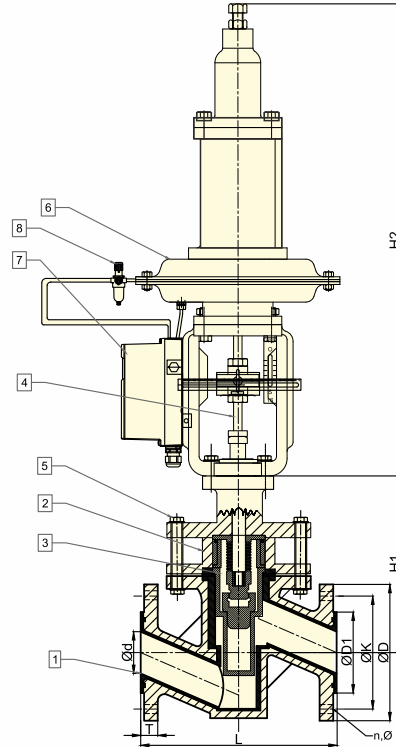

PART LIST

PART NO.	DESCRIPTION	MATERIAL OF CONSTRUCTION	QTY.
1	Body	ASTM A 216 GR. WCB + PFA LINED	1
2	Bonnet	ASTM A 216 GR. WCB + PFA LINED	1
3	Bellow	PTFE (STANDARD / HEAVY DUTY)	1
4	Stem	SS 316 / HASTELLOY-C	1
5	Fastners	ASTM A 193 GR. B7 / ASTM A 194 GR. 2H / SS 304	UPTO 50NB - 04NOS 80NB & ABOVE - 08NOS
6	Actuator	CI EPOXY PAINTED	1
7	Positioner	TO CUSTOMER REQUEST	1
8	Air Filter Regulator	TO CUSTOMER REQUEST	1
-	Solenoid Valve	TO CUSTOMER REQUEST	1

DIMENSIONS

Size NB (Ød)	ØD ±0.12		L ±0.12		ØD ±0.04		ØK1 ±0.04		ØK ±0.062		T +0.11/-0.00		n	Ø		H1		H2	
INCH	INCH	MM	INCH	MM	INCH	MM	INCH	MM	INCH	MM	INCH	MM		INCH	MM	INCH	MM	INCH	MM
½"	0.49	12.5	5.11	130	3.74	95.0	1.37	35	2.36	60	0.59	15.00	4	0.63	16	6.50	165	26.30	670
¾"	0.74	19	5.90	150	4.13	105	1.69	43	2.75	70	0.59	15.00	4	0.63	16	7.16	182	26.30	670
1"	0.98	25	6.20	160	4.25	108	2.00	51	3.11	79	0.49	12.50	4	0.63	16	7.16	182	26.30	670
1½"	1.50	38	7.87	200	5.00	127	2.87	73	3.86	98	0.70	18.00	4	0.63	16	9.76	248	26.30	670
2"	1.97	50	9.00	230	5.98	152	3.62	92	4.76	121	0.70	18.00	4	0.75	19	10.10	258	26.30	670
3"	2.95	75	12.20	310	7.48	190	5.00	127	5.98	152	0.86	22.00	8	0.75	19	11.40	290	27.40	697
4"	3.93	100	13.70	350	9.01	229	6.18	157	7.52	191	0.94	24.00	8	0.75	19	13.00	331	27.40	697

NOTE: 1. ACTUATOR CAN BE PROVIDED WITH MANUAL HAND WHEEL ON CUSTOMER REQUEST
2. TOLERANCES ARE GIVEN IN INCHES

PRODUCT DESIGN AND TESTS PERFORMED

DESIGN PARAMETERS	STANDARD
DESIGN STD	API 600 / BS 1873
SHELL DESIGN	ANSI B 16.34
FACE TO FACE DIM.	EN 558 SERIES 1
FLANGE CONNECTION RATING	ANSI B 16.5, 150# / DIN PN 10
TESTING STANDARD	BS EN 12266-1
CONNECTION	FLANGED, RF

TEST PERFORMED	BS EN 12266-1
SIZES	½" TO 4"
HIGH PR. SHELL TEST HYDRO	225 PSI (15 kg/cm ²)
HIGH PR. SEAT TEST HYDRO	165 PSI (11 kg/cm ²)
LOW PR. SEAT PNEUMATIC	75 PSI (5 kg/cm ²)

SPARK TEST	KVDC
SPARK TEST	20 KVDC

VALVE C_v & TORQUE VALUES

Size		C _v @ 100% OPENING	ACTUATOR MODEL	
INCH	MM		PN 3.5	PN 10
½"	15	4	UNP 20M LPA	UNP 20M LPA
¾"	20	7	UNP 20M LPA	UNP 20M LPA
1"	25	10	UNP 20M LPA	UNP 30M LPA
1½"	40	24	UNP 30M LPA	UNP 30M LPA
2"	50	43	UNP 30M LPA	UNP 30M LPA
3"	80	99	UNP 50M LPA	UNP 50M LPA
4"	100	153	UNP 50M LPA	UNP 60M LPA

NOTE :

- GLOBE VALVE CAN BE PROVIDED FOR SMALL C_v FROM 0.012 ONWARD
- GLOBE VALVE CAN BE PROVIDED FOR TRAVEL OF 15MM AS WELL AS 20MM
- GLOBE VALVE CAN BE PROVIDED WITH SINGLE ACTING AS WELL AS DOUBLE ACTING ACTUATOR

PRESSURE - TEMPERATURE GRAPH

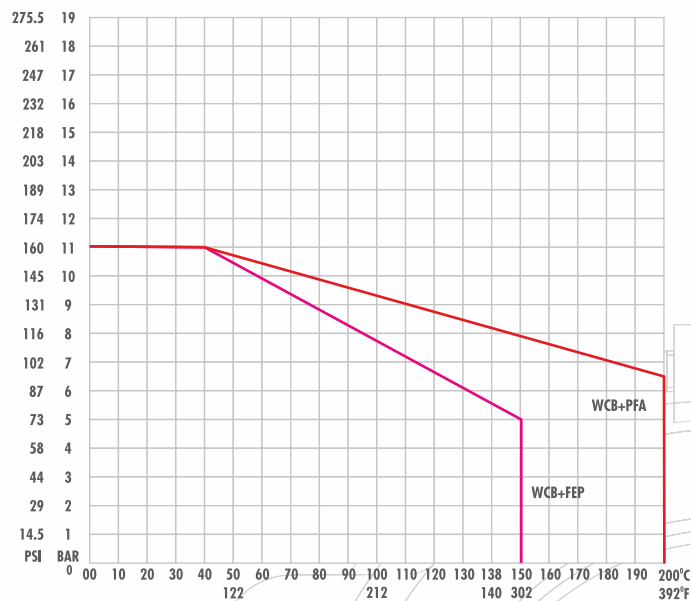

MOUNTING ACCESSORIES

ACTUATOR DETAILS

ACTUATOR OPTIONS	SINGLE ACTING / DOUBLE ACTING
ACTUATOR TYPE	RACK & PINION
ACTUATOR MAKE	ELOMATIC / ROTEX OR ANY OTHER MAKE SPECIFIED BY CUSTOMER
ACTUATOR AIR SUPPLY PRESSURE	3.5/4/5/6 BAR OR AS PER CUSTOMER REQUIREMENT
ACTUATOR MOC	DIE CAST ALUMINIUM / CF8 OR CF8M



SOLENOID VALVE

SOV TYPE	3/2 WAY OR 5/2 WAY NAMUR OR NON NAMUR
SOV MAKE	ASCO / ROTEX OR AS SEPCIFIED BY CUSTOMER
SOV COIL RATING	24V / 110VDC OR 110 / 220VAC
SOV COIL INSULATION CLASS	F OR H
SOV COIL HOUSING	WEATHER PROOF / FLAME PROOF / IS
SOV BODY MATERIAL	ALUMINIUM / SS316 / SS316L
SOV GLAND CONNECTION	1/4" / 1/2" / 3/4" NPT



ACTUATOR DETAILS

ACTUATOR OPTIONS	ON / OFF / MODULATED / CONTROL UNIT (INTEGRAL STARTER)
ACTUATOR TYPE	i-TORK
ACTUATOR MAKE	WEATHERPROOF / FLAMEPROOF
ACTUATOR SUPPLY VOLTAGE	110 / 220 VAC (1 Ph) / 50 / 60 Hz 380 / 440mVAC (3 Ph) / 50 / 60 Hz 24 VDC
ACTUATOR ENCLOSURE	1/4" / 1/2" / 3/4" NPT



MOUNTING ACCESSORIES

POSITIONER

POSITIONER MAKE	YTC / SIEMENS OR AS PER CUSTOMER REQUIREMENT
POSITIONER TYPE	E2P NORMAL / SMART / HART
POSITIONER HOUSING TYPE	WEATHERPROOF / FLAMEPROOF
POSITIONER BODY MOC	DIE CAST ALUMINIUM / SS304 / SS316
PNEUMATIC CONNECTION	¼" / ½" / ¾" NPT



AIR FILTER REGULATOR

AFR MAKE	SHAVO NORGREN / PLACKA OR AS SPECIFIED BY CUSTOMER
AFR FILTER OPTIONS	5 MICRONS / 25 MICRONS
AFR BODY MOC	DIE CAST ALUMINIUM OR SS304 / SS316
AFR PNEUMATIC CONNECTION	¼" / ½" / ¾" NPT



LIMIT SWITCH

LIMIT SWITCH TYPE	PROXIMITY SENSOR TYPE OR MECHANICAL SWITCHES SPDT / DPDT
LIMIT SWITCH MAKE	ELOMATIC / ROTEX / SEIMENS OR AS SPECIFIED BY CUSTOMER
NO.OF SWITCHES OFFERED	1 NO + 1 NC OR 2 NO + 2 NC OR AS SPECIFIED BY THE CUSTOMER
LIMIT SWITCH HOUSING	WEATHERPROOF / FLAMEPROOF



CERTIFICATION

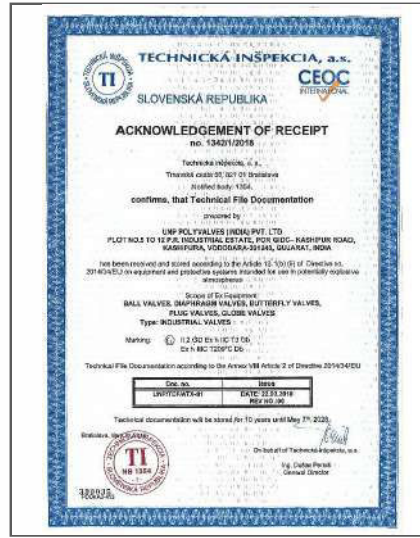
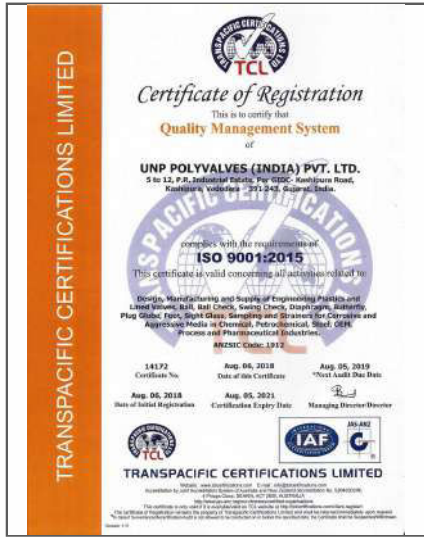

APPROVED
ISO 15848-1
 FUGITIVE EMISSION CERTIFICATION
**PFA LINED SIDE SPLIT
 FULL PORT BALL VALVES**
 Size Range : 1/2" to 6"

APPROVED
ISO 15848-1
 FUGITIVE EMISSION CERTIFICATION
PFA LINED PLUG VALVES
 Size Range : 1/2" to 8"

APPROVED
ISO 15848-1
 FUGITIVE EMISSION CERTIFICATION
PFA LINED BUTTERFLY VALVE
 Size Range : 2" to 24"

APPROVED
DIN EN 14432:2014
PFA LINED BUTTERFLY VALVES
 Size Range : 2" to 8"

APPROVED
DIN EN 14432:2014
**PFA LINED SIDE SPLIT
 DESIGN BALL VALVES**
 Size Range : 1" to 4"



VADODARA



CORPORATE OFFICE

946, GIDC, Makarpura,
Vadodara - 390 010, INDIA
Phone : +91 - 265 - 2649248, 2632628
Fax : +91 - 265 - 2637379
Email : sales.baroda@polyvalve.com | mktg@polyvalve.com

FACTORY

5 to 12 PR Industrial Estate,
Por GIDC - Kashipura Road,
Moje : Kashipura - 391 243,
Dist. Vadodara, INDIA
Phone : +91 70434 30467/77 , 70430 20707

MUMBAI

THANE

207, Orion Business Park, Next to Cine Max, Kapurbawdi,
Ghodbunder Road, Thane (W) - 400 607. INDIA.
Phone : +91 - 22 - 25896422, 25896524 / 25
Fax : + 91 - 22 - 2589 - 4221
Email : sales.thane@polyvalve.com | mktg@polyvalve.com

USA



DJK - Energy Houston

BRANCH OFFICE

DJK-ENERGY HOUSTON INC.
13201, NW FWY, Suite 800,
Houston, Texas - 77040, USA
Phone : +1 832 213 9674
Email : djk@linedvalvesamerica.us

www.polyvalve.com | www.polyvalve.in

AUTHORISED DISTRIBUTOR FOR
Australia/NZ/PNG/Philippines

RHINO FLEX™

RHINOFLEX VALVE SOLUTIONS PTY.LTD

4/7 Holder Way, Malaga, W.A 6090

Phone: +61 -08 61130808

sales@rfvs.com.au

ISO 9001:2015



- UNP Polyvalves reserves the right, without notice to alter improve the designs, specifications, dimensions of the products described herein.
- UNP Polyvalves does not assume any responsibility for the data given in this brochure. It is necessary for the customers to carry out necessary tests before selecting the MOC for their applications.